



RHINO-RACK

Aerodynamic & Heavy Duty Roof Rack Systems

RABK Rhino Commercial - Aerial Bracket (Heavy Duty)

Place these instructions in the vehicle's glove box after installation is complete.

Important: Please read these instructions carefully prior to installation.
Please refer to your fitting instruction to ensure that the roof racks are installed in the correct locations.

Parts List

Important: Check the contents of kit before commencing fitment and report any discrepancies.

Item	Component Name	Qty.	Part No.
1	M8 x 20mm Hex Head Setscrew	1	B020
2	M8 Shake Proof Washer	1	W033
3	Aerial Bracket	1	A115
4	M8 Channel Nut	1	N003
5	Fitting Instruction	1	RR76

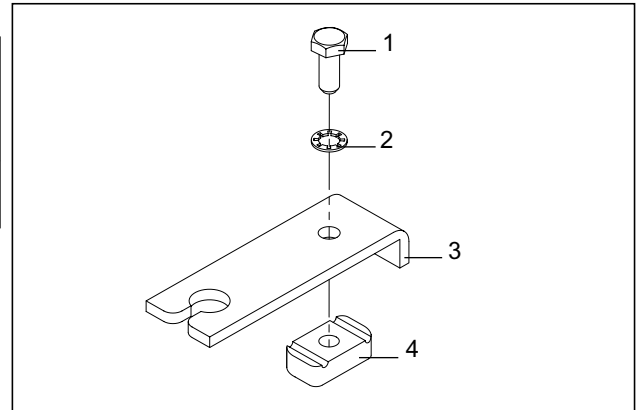

Locate the aerial bracket to the top recess of the crossbar.

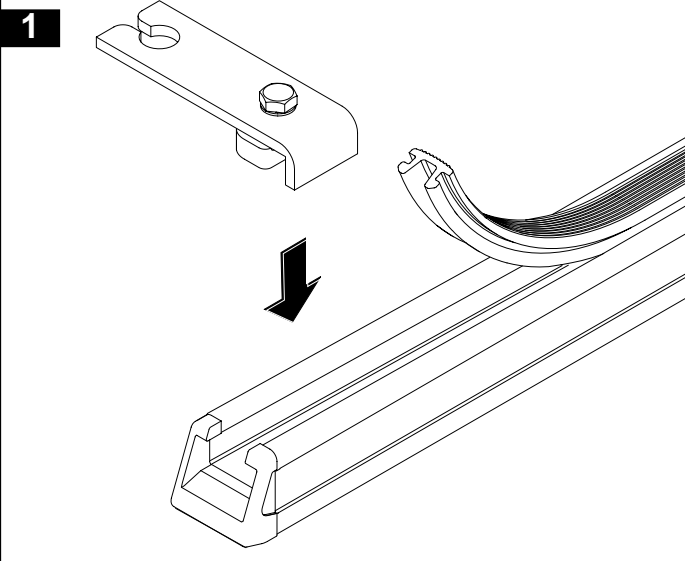

Locate the channel nut into the crossbar recess, turn the attachment bolt so that the channel nut rotates and locates across the crossbar. Adjust the position of the bracket and tighten the attachment bolt. Check that the channel nut is fully located across the crossbar after tightening. Trim rubber buffer strip to suit.

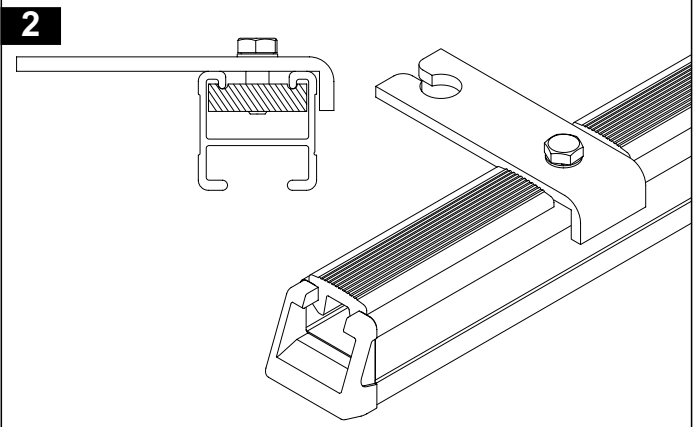

Mount aerial onto aerial bracket.

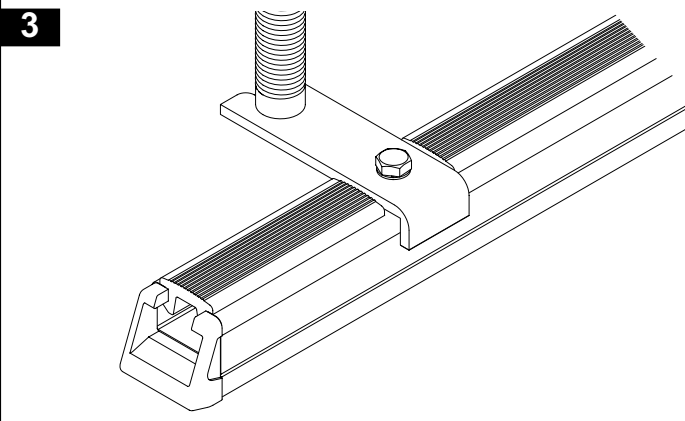

Rhino-Rack
3 Pike Street, Rydalmere,
NSW 2116, Australia.
(Ph) (02) 9638 4744
(Fax) (02) 9638 4822

Prepared By: Sheila Oliveira
Authorised By: Gary England

Document No: RR-76
Issue No: 02
Issue Date: 20/06/2003

These instructions remain the property of Fetovu Pty Ltd T/as Rhino-Rack and may not be used or changed for any other purpose than intended.