

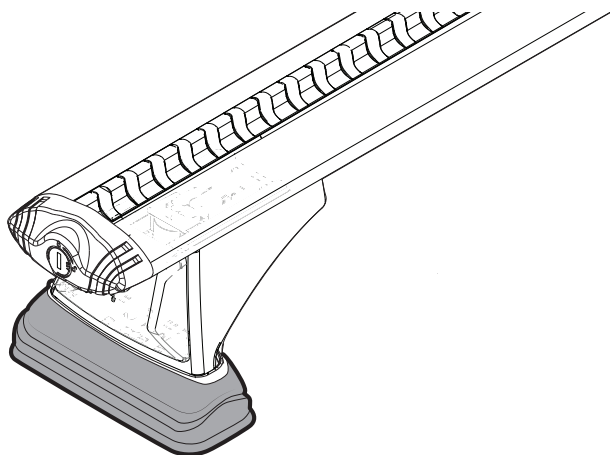

RHINO-RACK

RCP47H-BK Base Kit



Date Purchased: _____

Date Fitted: _____

Fitment By: _____

Km/Mi at Fitment: _____

Maximum carrying capacity: _____

Vehicle	On Road Cargo Allowance	Off Road Cargo Allowance	Roof Allowance	Rack Weight (2.5kg per bar)
VW Caddy/ Caddy Maxi MY11 - on 3 bar (when used in conjunction with RCP47-BK).	92kg / 202lbs	61kg / 134lbs	100kg / 220lbs	7.5kg / 11lbs
Mitsubishi Triton Dble Cab/ 2dr Club Cab 04/15 on 1 bar	35kg / 77lbs	24kg / 52lbs	40kg / 88lbs	5kg / 11lbs

- Off Road:** Any driven path taken that is not on sealed (tarred / bitumen) and maintained
- Roof Allowance:** Total permissible weight attached to the roof of the car. This is inclusive of the weight of the roof rack system
- Cargo Allowance:** Total permissible weight allowed on top, and attached to roof racks whilst the vehicle is in motion
- Static Allowance:** Total permissible weight allowed on top, and attached to roof racks whilst the vehicle is stationary
- Load must be evenly distributed over the roof racks. Weight of roof rack accessories is to be included in cargo allowance.

Torque settings

Unless stated otherwise in these instructions, all fasteners should be set to the following torque settings - M6: 4-5Nm (3-4lbs/ft), M8: 8-10Nm (6-7.5lbs/ft) and M10: 16-18Nm (12-13lbs/ft).

Warning: _____

- Check the Rhino-Rack website to ensure you have the latest issue of the instructions
- Check Part No. and / or Kit is correct for use with your vehicle
- Do not attempt to fit the rack system to your vehicle unless you fully understand these fitting instructions. Please direct any questions regarding fitting to the dealer from where the roof racks were purchased.
- **Use only non-stretch fastening ropes or straps.**
- The handling characteristics of the vehicle changes when you transport a load on the roof. For safety reasons we recommend you exercise extreme care when transporting wind-resistant loads. Special consideration must be taken into account when cornering and braking.
- Although the system is tested and approved to AS1235-2000 / ISO 11154, off-road conditions can be much more rigorous. Extreme care must be taken in off road conditions

Recommendations: _____

It is essential that all bolt connections be checked after driving a short distance when you first install your roof racks. Bolt connections should be checked again at regular intervals (once a week is enough, depending on road conditions, usage, loads and distances travelled). You should also check the roof racks each time they are re-fitted. Always make sure to fasten your load securely. Please also ensure that all loads are evenly distributed and that the centre of gravity is kept as low as possible and must be entirely contained within the extents of the roof racks.

Note for Dealers and Fitters: _____

It is your responsibility to ensure these fitting instructions are given to the end user or client.

Rhino-Rack, 22 Hanson Pl, Eastern Creek
 NSW 2766, Australia
 (02) 8846 1900
 rhinorack.com.au

Document No: R1905
 Issue No: 01
 Issue Date: 13/08/2019

These instructions remain the property of Rhino-Rack Australia Pty. Ltd. and may not be used or changed for any other purpose than intended.

RCP47H-BK Base Kit

Parts List

Item	Components	Qty
1	Short Fixed Mount Rotation Block	2
2	Short Fixed Mount Base Cover	4
3	Short Fixed Mount Base	2
4	Tall Fixed Mount Flat Rubber	2
5	M6 x 35mm Hex Setscrew	2
6	M6 Spring Washer	2
7	M6 16mm Flat Washer	2
8	M8 Fix Point Adaptor	2
9	Instructions	1

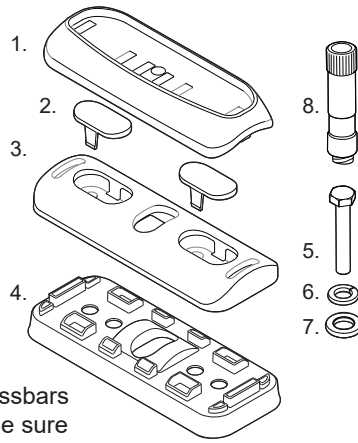

Locking RCL Low Leg

80mm

Locking RCH High Leg

105mm

Tools Required: 1. 10mm socket wrench
2. 5mm Allen Key (Caddy only)
3. Drill and 3 + 11mm drill bit (Triton only)
4. Dremel (Triton only)

Note: Legs and Crossbars are sold separate. Be sure to obtain correct kits for your vehicle.

Prepare the base kit

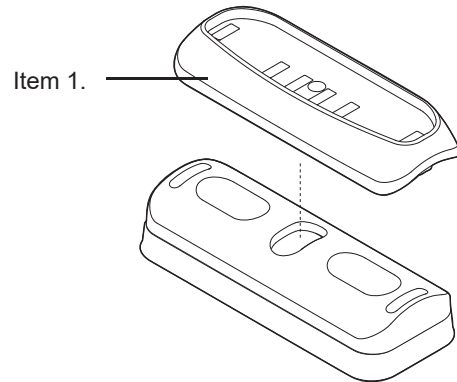
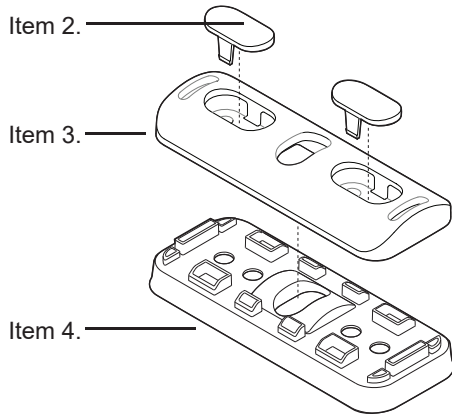

Mitsubishi Triton Instructions single bar (for VW Caddy, turn to pg5)

1 4dr double cab (for 2dr club cab turn to pag 3).

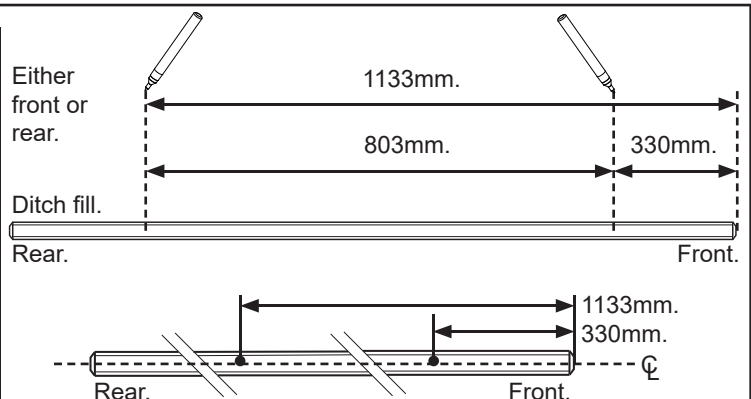
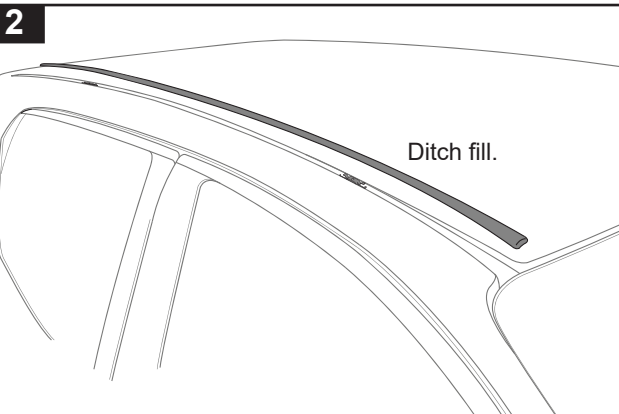
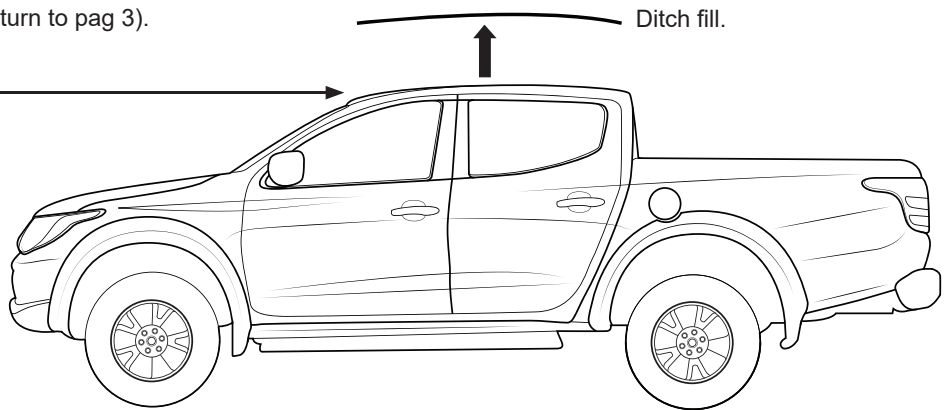
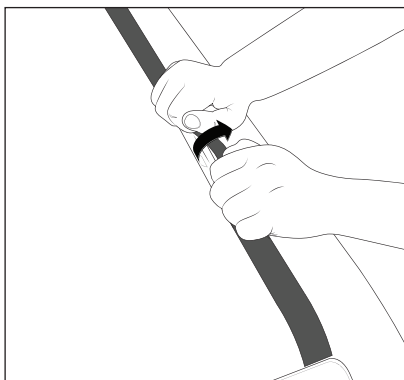

RCP47H-BK Base Kit

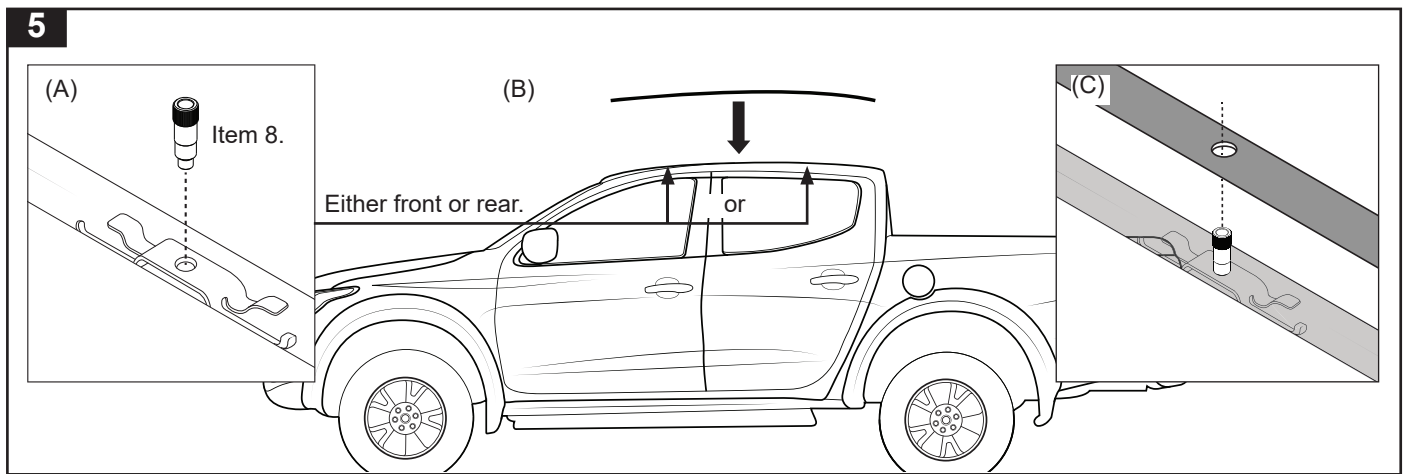
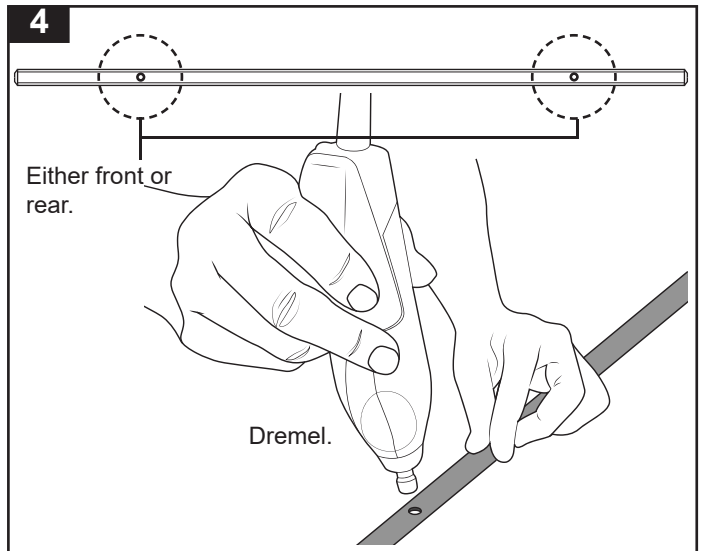
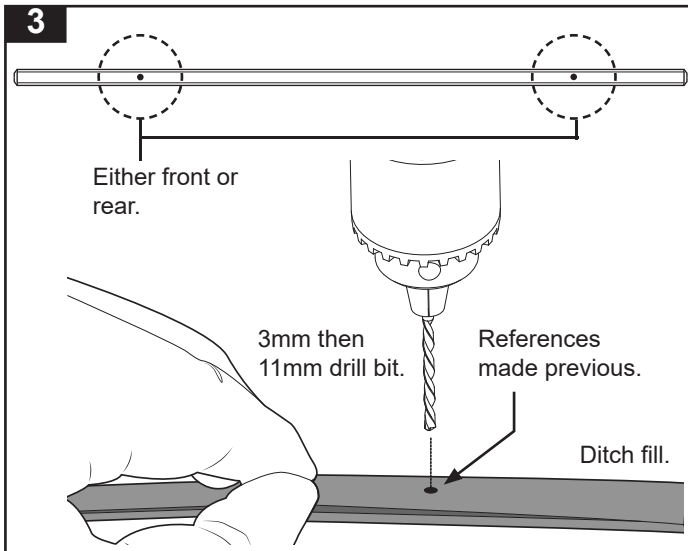

Mitsubishi Triton Club Cab single bar

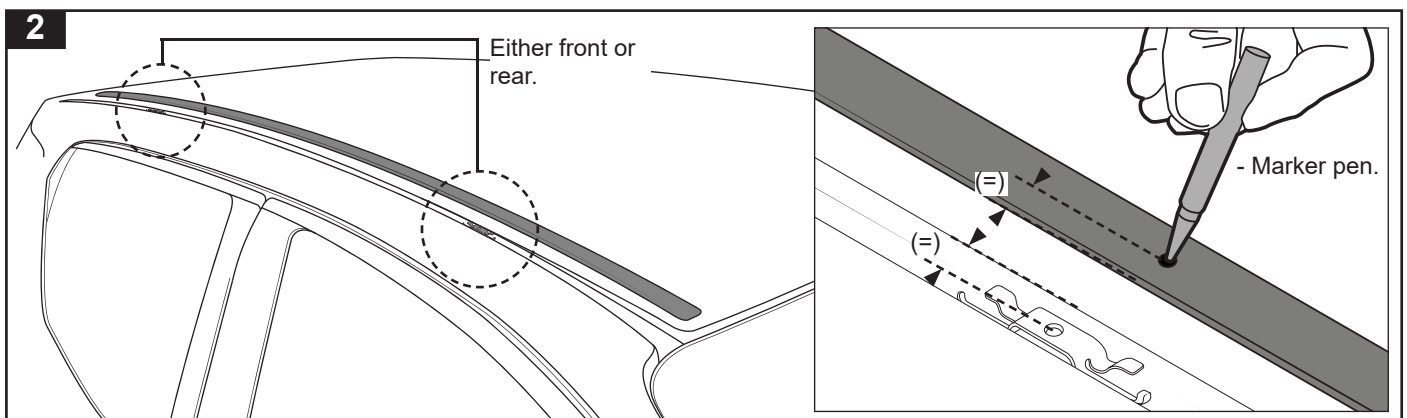
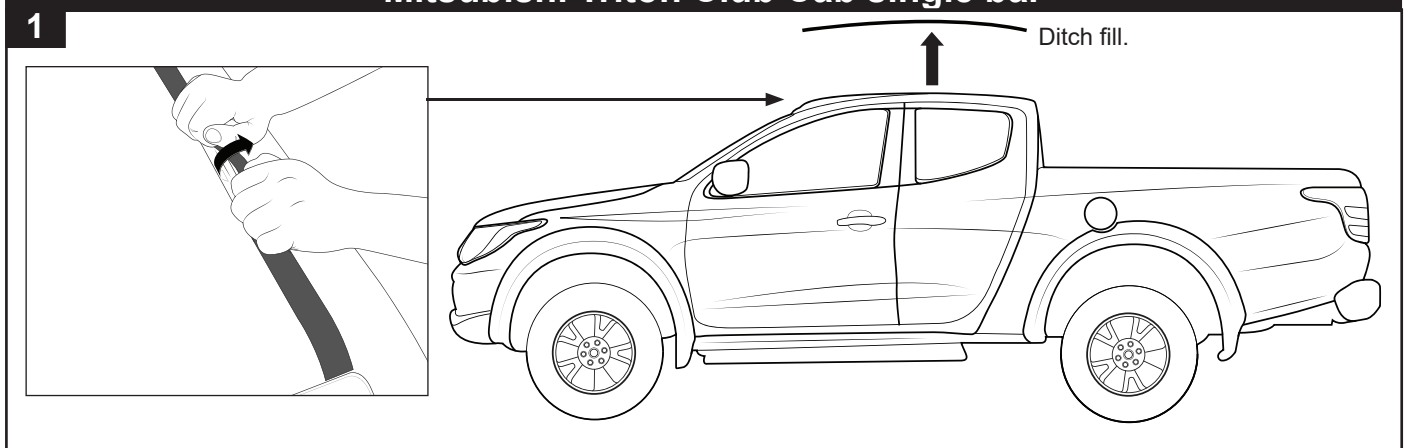

RCP47H-BK Base Kit

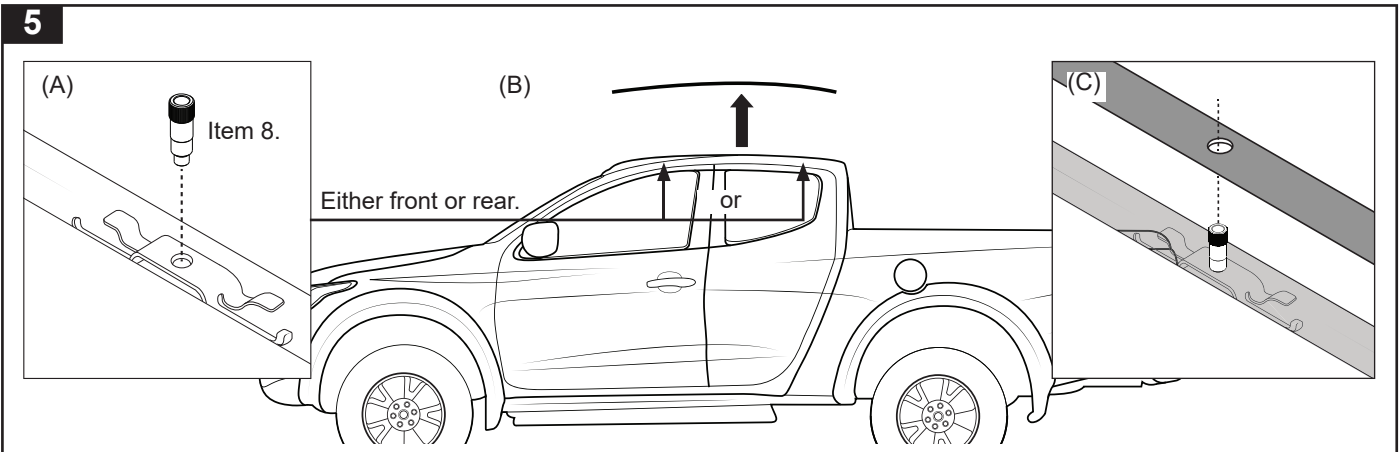
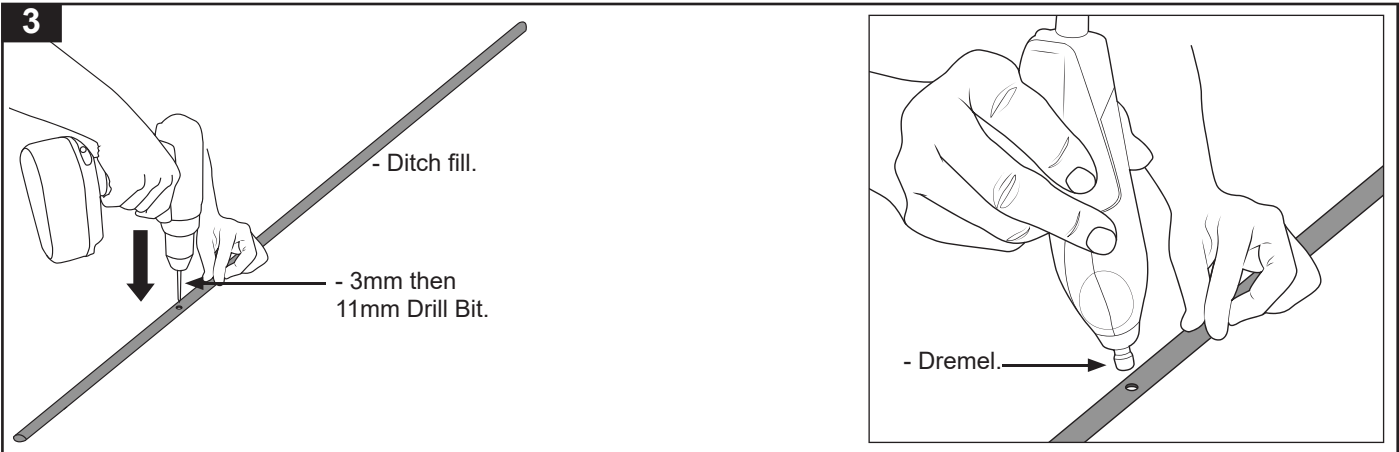

Installing the leg kit

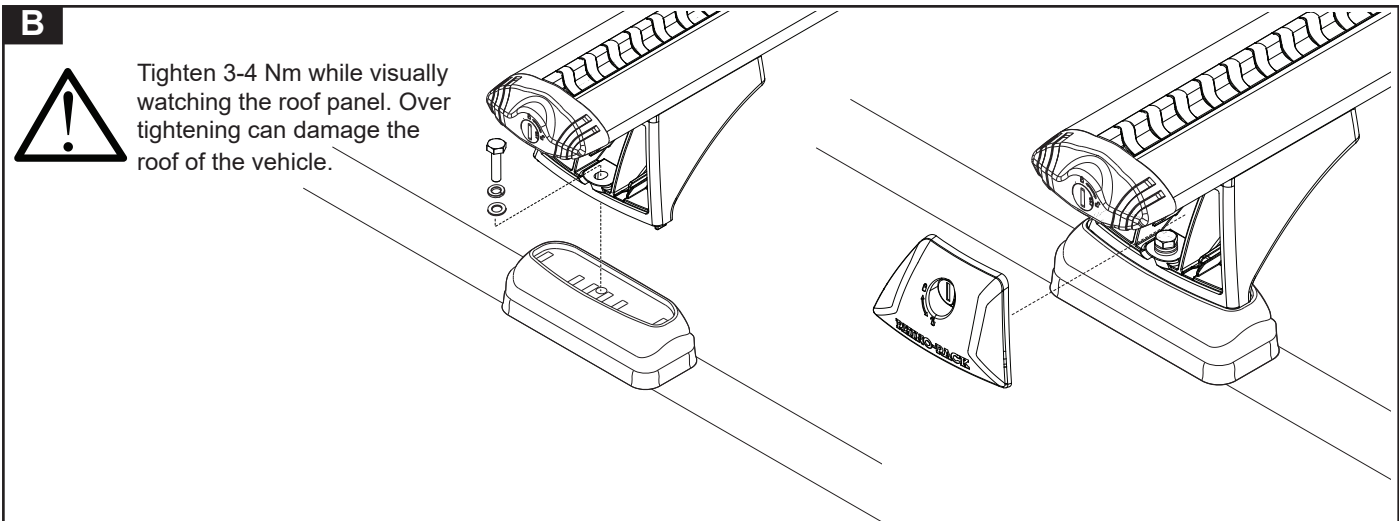
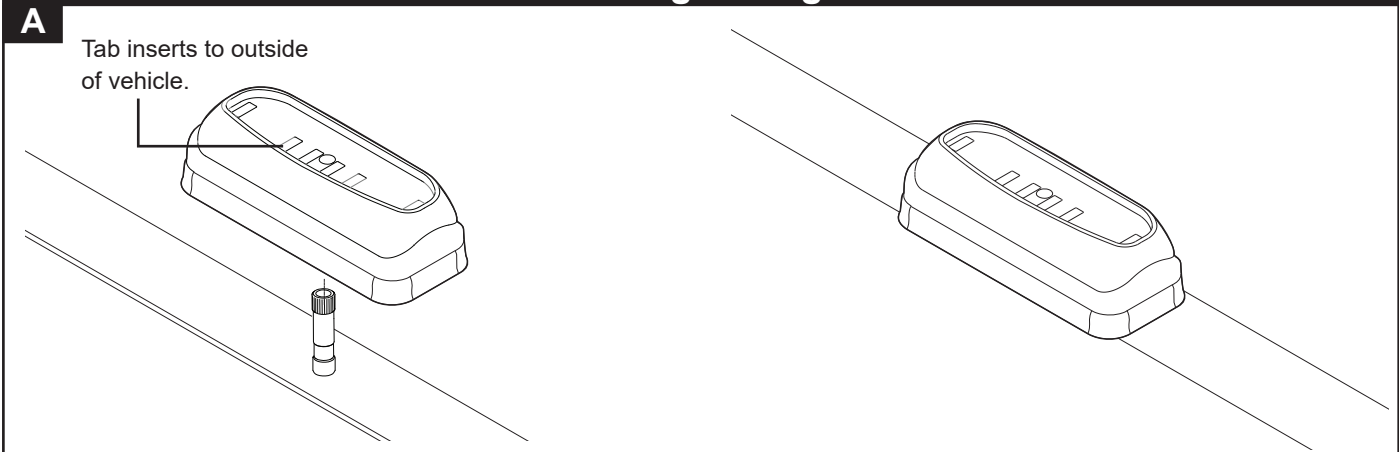

RCP47H-BK Base Kit

VW Caddy/ Caddy Maxi MY11 on Instructions

1A Volkswagen Caddy

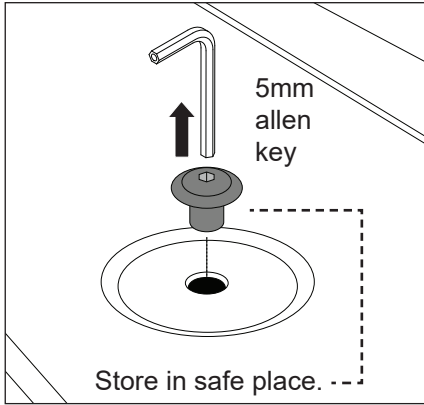

3 Crossbars:
Front, middle and rear mount points used. Additional RCP47-BK required.

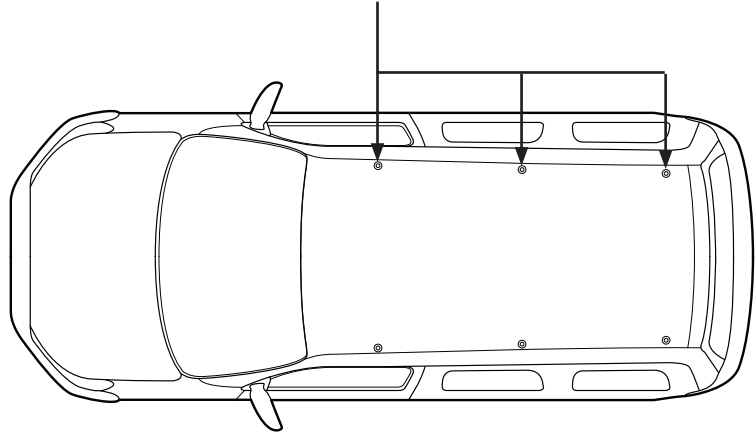

1B Volkswagen Caddy Maxi

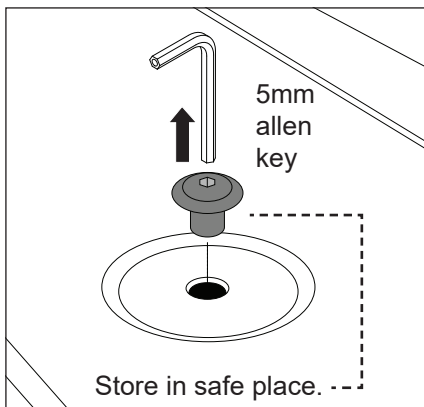

3 Crossbars:
Front, middle and rear mount points used. Additional RCP47-BK required.

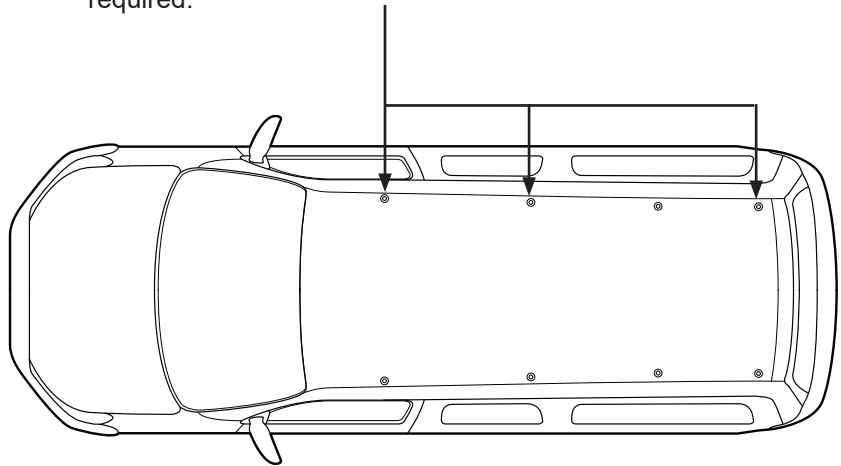

2

Tab inserts to outside of vehicle.

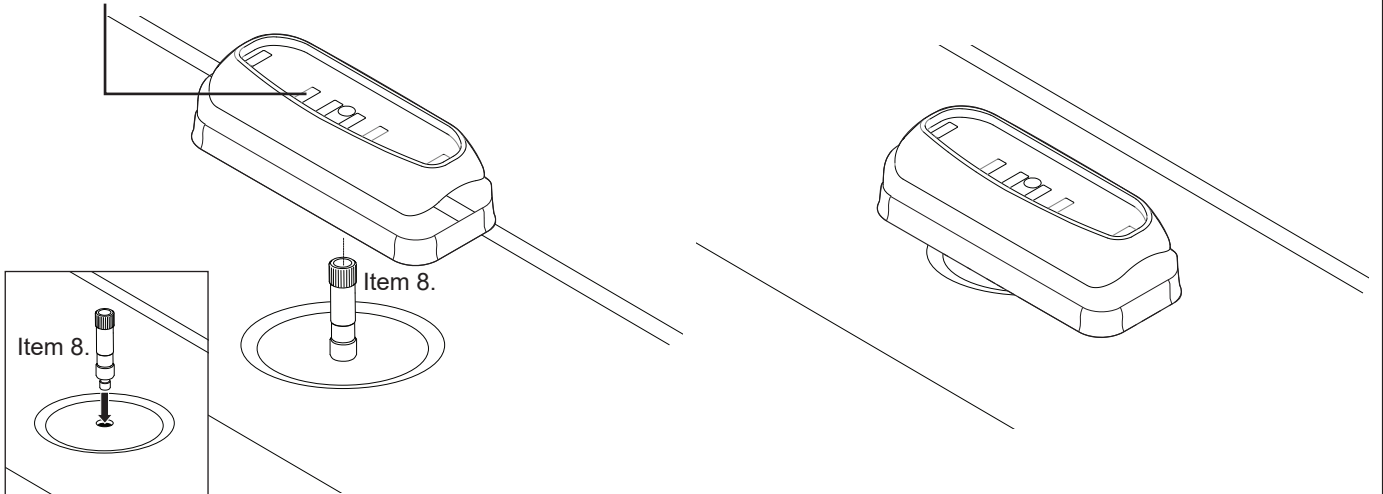

RCP47H-BK Base Kit

VW Caddy Leg Setup 3 Bar

Vortex 3 bar system:

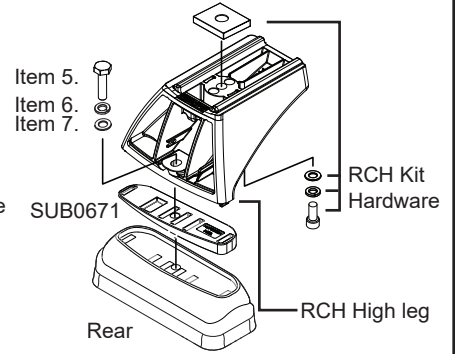
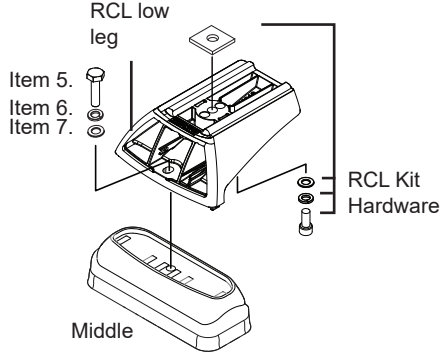
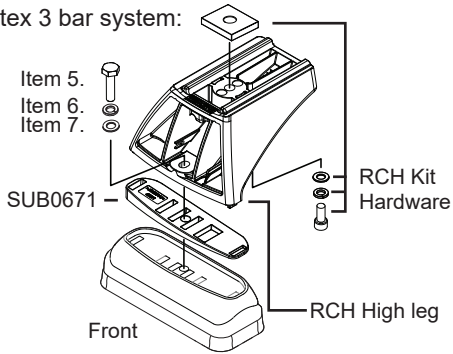

Heavy Duty 3 bar system:

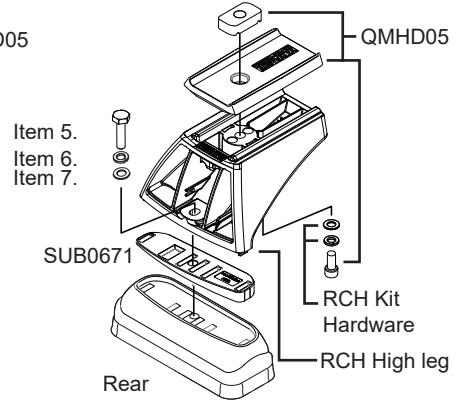
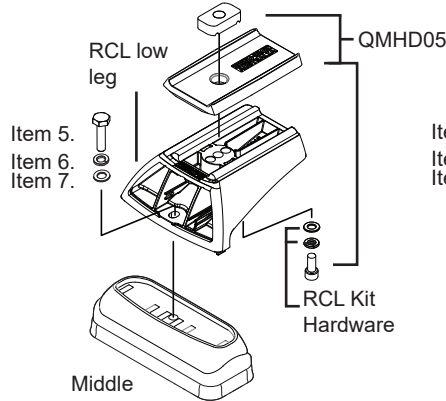
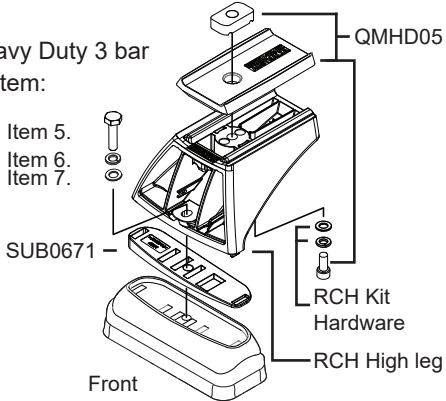

VW Caddy Maxi Leg Setup 3 Bar

Vortex 3 bar system:

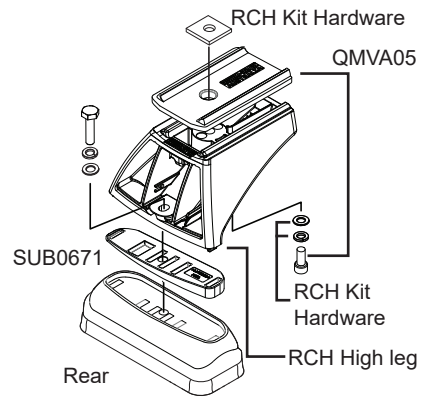
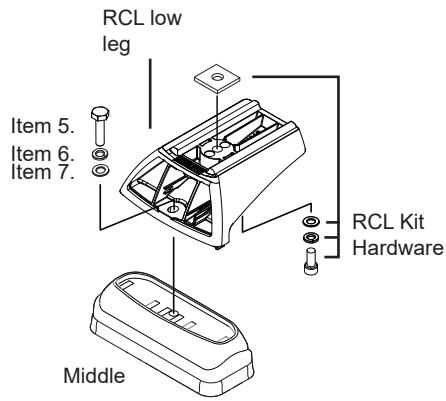
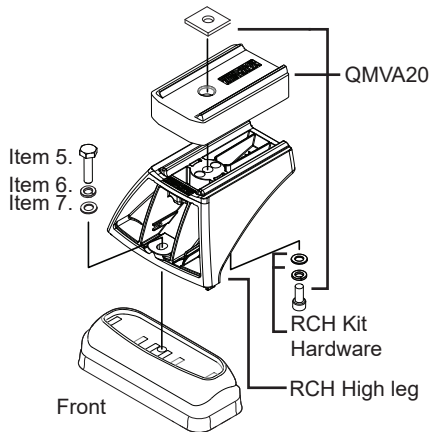

Heavy Duty 3 bar system:

