



RHINO-RACK

Aerodynamic & Heavy Duty Roof Rack Systems

RSLP, RMLP & RLLP Rhino Commercial - Ladder Peg Small, Medium & Large.

Place these instructions in the vehicle's glove box after installation is complete.

Important: Please read these instructions carefully prior to installation. Please refer to your fitting instruction to ensure that the cross bars are installed in the correct locations. Check the contents of the kit before commencing fitment and report any discrepancies.

Parts List

Item	Component Name	Qty	Part No.
1A	Ladder Peg - Small	2	C451
1B	Ladder Peg - Medium	2	C418
1C	Ladder Peg - Large	2	C419
2	Rubber Tube	2	R048
3	M12 Channel Nut	2	N012
4	Eye Bolt Base	2	C420
5	Fitting Instruction	1	RR-145

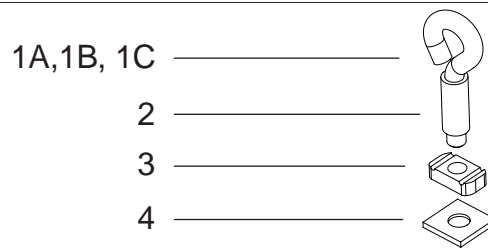

Screw the Ladder peg into the Channel nut. Make sure the two grooves on the Channel nut face upwards as shown.

1

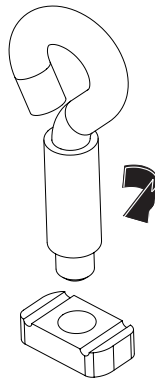

Remove rubber buffer strip. Slide the Eye bolt base with the recess facing up into the top of the cross bar. With the Ladder peg and Channel nut attached slide into the top of the cross bar.

2

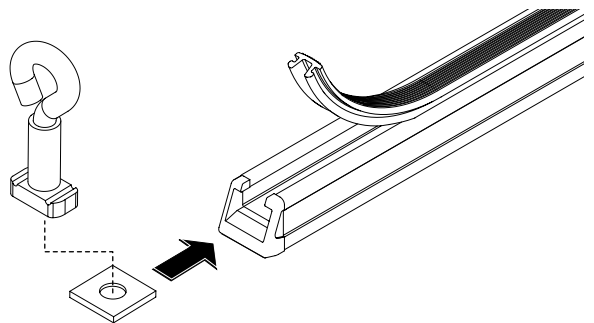

Position the Ladder peg, then tighten to secure. It is very important that the Channel nut is fully located across the cross bar. Trim the rubber buffer strip to fill the gap either side of the Ladder peg.

3

Channel nut must be located across the bar as shown.

Eye bolt base.

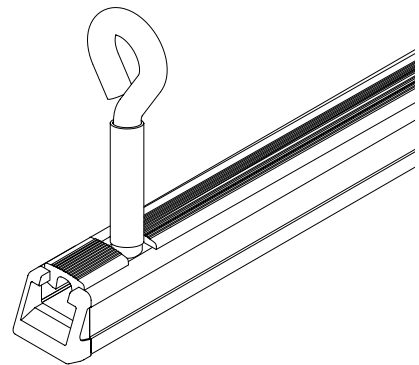
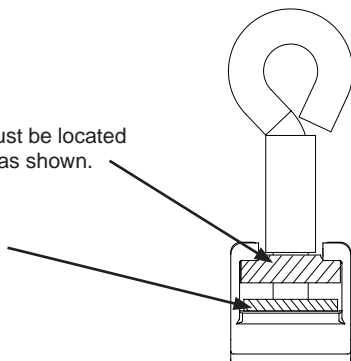

Rhino-Rack

3 Pike Street, Rydalmere,
NSW 2116, Australia.
(Ph) (02) 9638 4744
(Fax) (02) 9638 4822

Document No: RR-145
Prepared By: Craig Jones
Authorised By: Gary England

Issue No: 01
Issue Date: 06/10/2006

These instructions remain the property of Fetovu Pty. Ltd. T/as Rhino-Rack and may not be used or changed for any other purpose than intended.