

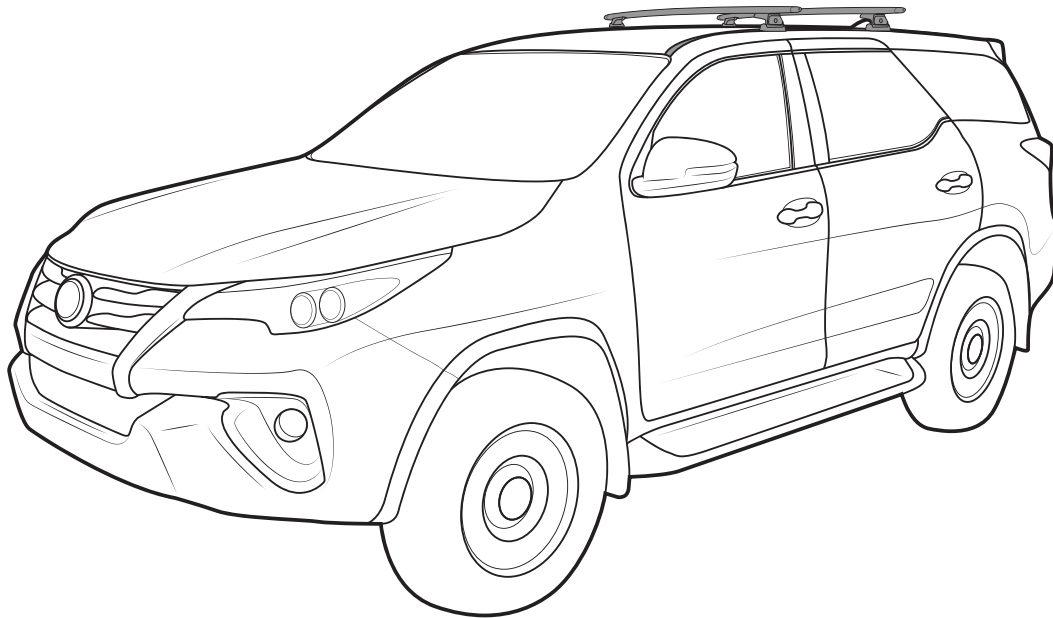

# RHINO-RACK

## Toyota Fortuner Trackmount Kit (RTS544)

**Important:** Please read these instructions carefully prior to installation. Please refer to your fitting instruction to ensure that the Roof Rack System is installed in the correct location. Check the contents of kit before commencing fitment and report any discrepancies. Place these instructions in the vehicle's glove box after installation is complete.



**Maximum load carrying capacity: 100kg / 220lbs**

### Important Information

1.  Check Part No./Kit is correct                      3.  Fit roof rack accessory
2.  Read through instruction before installing      4.  Check and recheck all fasteners are secure

**Maximum carrying capacity:** 100kg (220lbs) including the weight of the rack system.

Please refer to your vehicle manufacturers handbook for maximum carrying capacity. Always use the lower of the two figures. Load must be evenly distributed over the entire basket.

**Warning:** Do not attempt to fit the rack system to your vehicle unless you fully understand these fitting instructions. Please direct any questions regarding fitting to the dealer from where the roof racks were purchased.

**Use only non-stretch fastening ropes or straps.**

**Recommendations:** It is essential that all bolt connections be checked after driving a short distance when you first install your roof racks. Bolt connections should be checked again at regular intervals (once a week is enough, depending on road conditions, usage, loads and distances travelled). You should also check the roof racks each time they are re-fitted. Always make sure to fasten your load securely. Please also ensure that all loads are evenly distributed and that the centre of gravity is kept as low as possible and must be entirely contained within the extents of the roof racks. **Rack System must be removed when putting vehicle through an automatic car wash.**

**Caution:** The handling characteristics of the vehicle changes when you transport a load on the roof. For safety reasons we recommend you exercise extreme care when transporting wind-resistant loads. Special consideration must be taken into account when cornering and braking.

**Off-road use:**

The Track Rack System may be used in off road applications, however a safety factor of 1.5 is enforced. That is, maximum permissible off road load is **67kg (147lbs)**. Although the crossbars are tested and approved to AS1235-2000/ 15011154, off-road conditions can be much more rigorous. Extreme care must be taken in off road conditions

**Note for Dealers and Fitters:**

It is your responsibility to ensure these fitting instructions are given to the end user or client.

Rhino-Rack 3 Pike Street, Rydalmere,

NSW 2116, Australia.

(Ph) (02) 9638 4744

(Fax) (02) 9638 4822

Document No: R967

Prepared By: Kayle Everett

Authorised By: Chris Murty

Fit Time: 1 Hour

Issue No: 02

Issue Date: 11/10/2017

These instructions remain the property of Rhino-Rack Australia Pty. Ltd. and may not be used or changed for any other purpose than intended.



# Toyota Fortuner Trackmount Kit (RTS544)

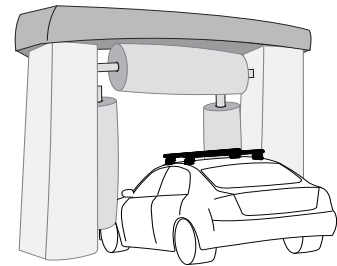
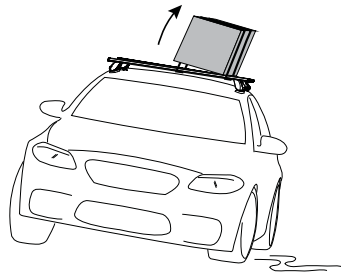
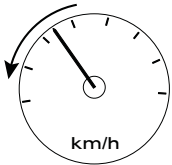
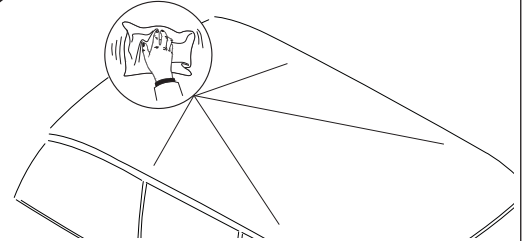
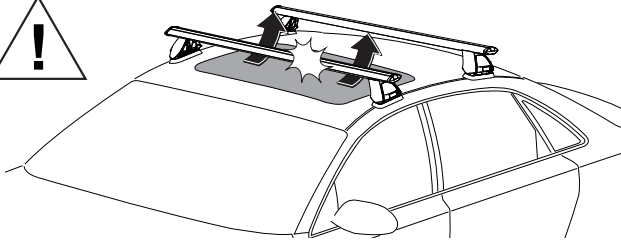
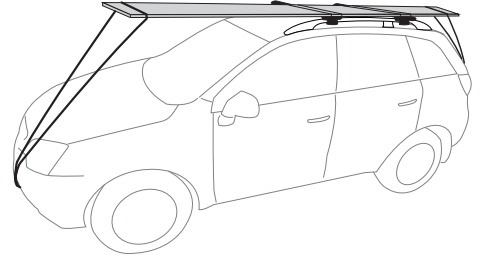
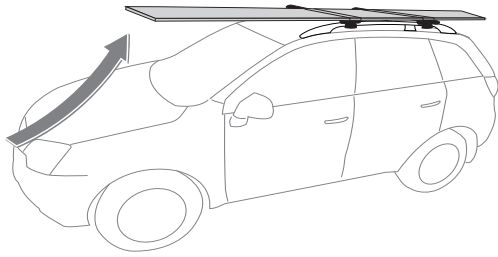

**Ensure Ladder is well supported on the ground to help support tent. Take extreme caution when climbing heights above 1.2m/4ft.**



? kg

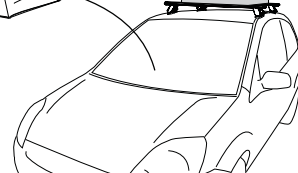

When these roof racks are to be used on a vehicle that is driven off sealed roads, the manufacturer maximum roof load rating (to be found in the vehicles User Manual) should be **divided by 1.5**. Do not forget to subtract the complete crossbar system weight from your maximum carrying capacity.

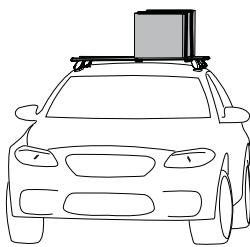

100kg/220lbs  
(Urban Road)



67kg/147lbs  
(Off Road)

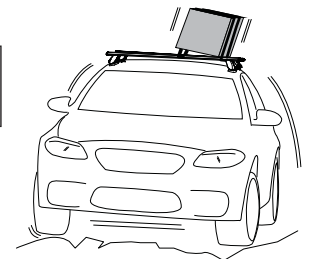

## WARNING! Important Load Carrying Instructions

With utility vehicles, the cabin and the canopy move independently. Roof racks and vehicle can be damaged if the item transported is rigidly fixed at points on both the cabin and canopy. Instead, rigidly fix to either the cabin roof racks or the canopy roof racks.

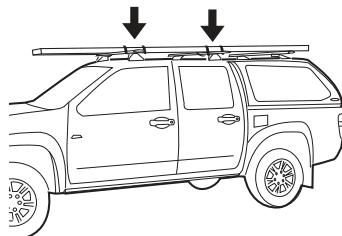
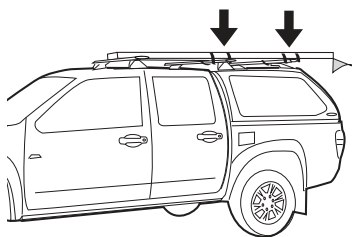

Paddle/ Surfboards should be fixed to the front of the vehicle.

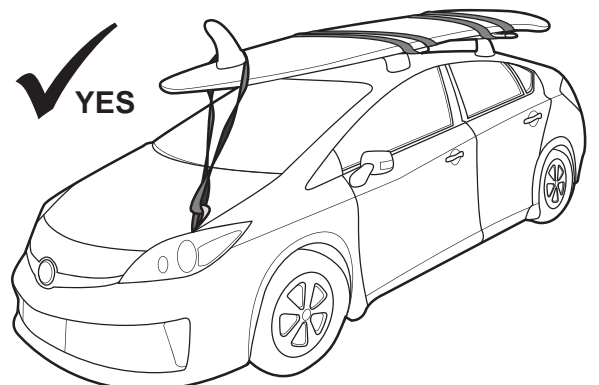



# Toyota Fortuner Trackmount Kit (RTS544)

## Parts List

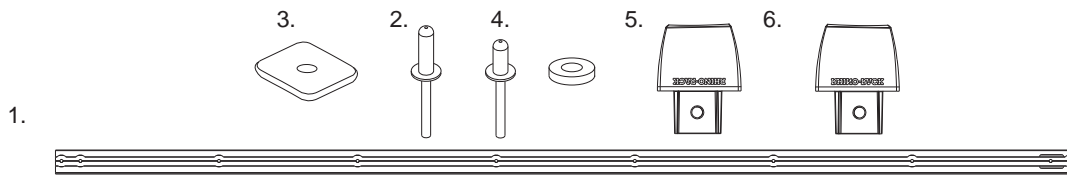

Item	RTS542 Kit	Qty	Part No.
1	Toyota Fortuner Track	2	A769
2	Stavex Rivet BS 11 4.8mm	18	H060
3	Rivet 1.6-6.3mm Grip	2	H004
4	Butyl Patch 20x20mm 4.5mm rivet hole	20	CA1397
5	End Cap FR,RL	2	M831
6	End Cap FL,RR	2	M832
7	Rivet Gun Spacer 4mm	1	CA1555
8	Instructions	1	R967

### Tools Required:

- |                   |                           |
|-------------------|---------------------------|
| 1. Measuring Tape | 5. Cold Galvanising Paint |
| 2. Drill          | 6. Cotton Buds            |
| 3. 5mm Drill Bit  | 7. Marker                 |
| 4. Drill Stop     | 8. Vacuum Cleaner         |

### Note:

**Crossbar Length: 1375mm**  
**Leg Kit: RLT600**

Crossbar and Leg Kits are sold as separate. Leg Spacer kits may be required for more than two crossbars.

## Instructions

- 1** Measure back from the windshield 390mm and create a reference mark on the mould.

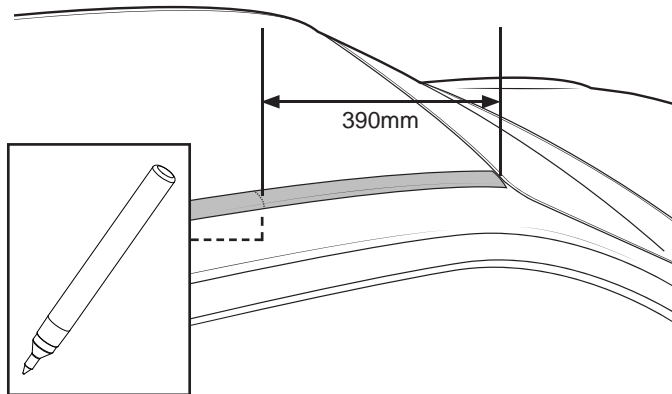

- 2** Lift the ditch mould out from the rear, stopping at the reference mark made previous, 390mm back from the windshield.

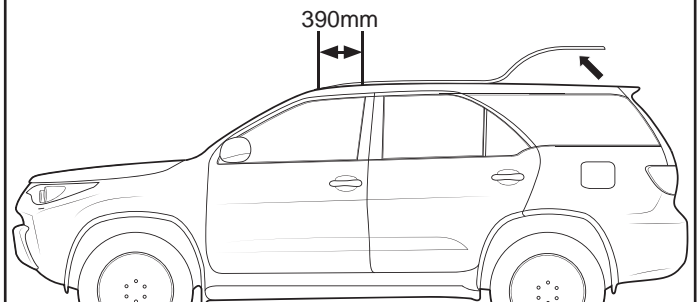

- 3** Cut the ditch mould with a blade at the reference line. Put the ditch mould to the side. Use care as to not damage the paintwork.

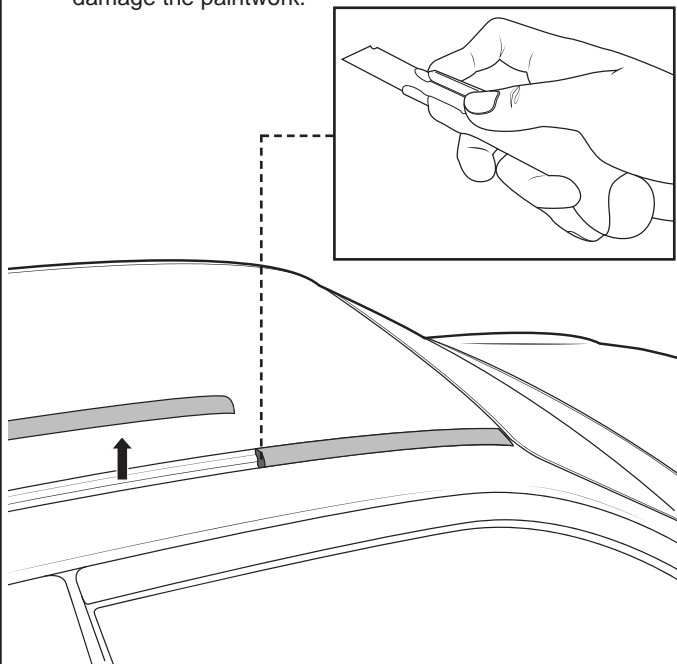

- 4** Place the Track into the ditch as shown. Be sure it sits hard up against the ditch mould left at the front of the vehicle.

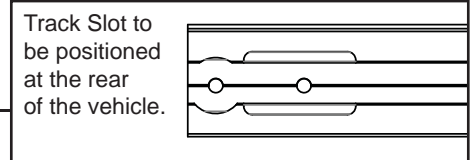
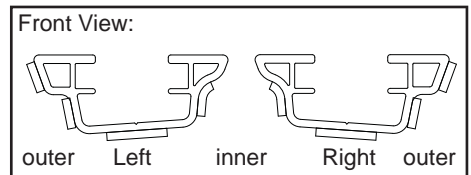

The Track should be flush with the cut ditch mould.

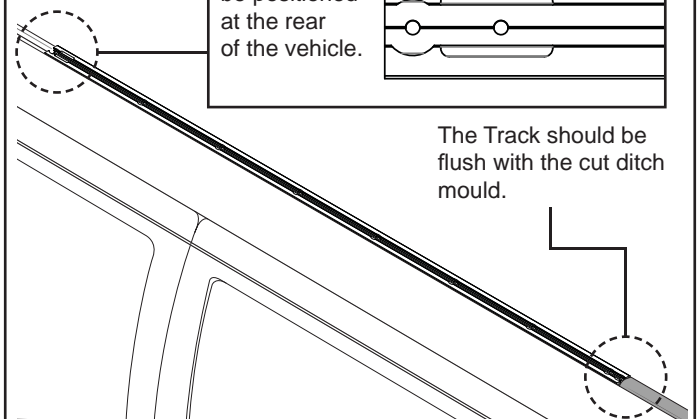



# Toyota Fortuner Trackmount Kit (RTS544)

**5** Measure the gap in the ditch at the rear of the vehicle

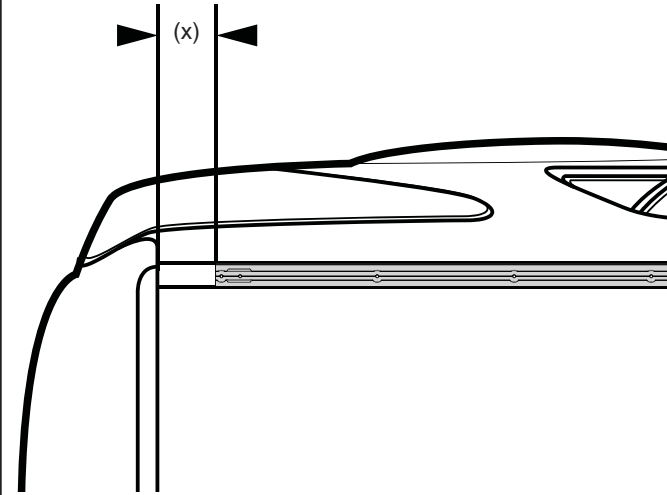

**6** Cut the rear of the ditch mould to this measurement (x). Check and re-check before cutting. Place this cut section of ditch mould back into position.

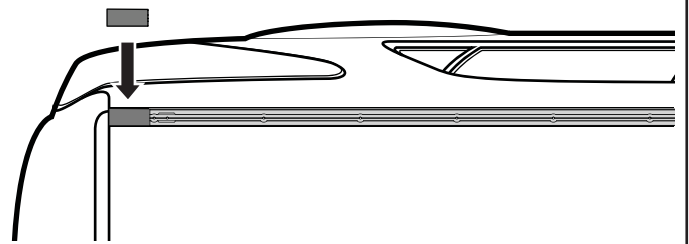
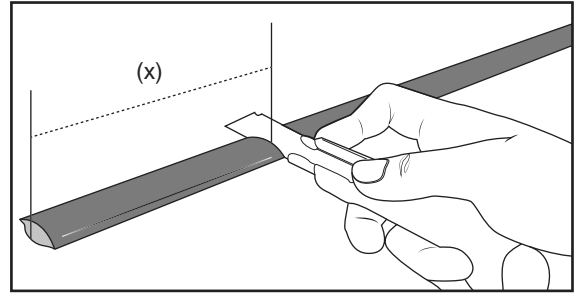

**7** Use a marker and create a reference in the ditch through each of the rivet holes in the track.

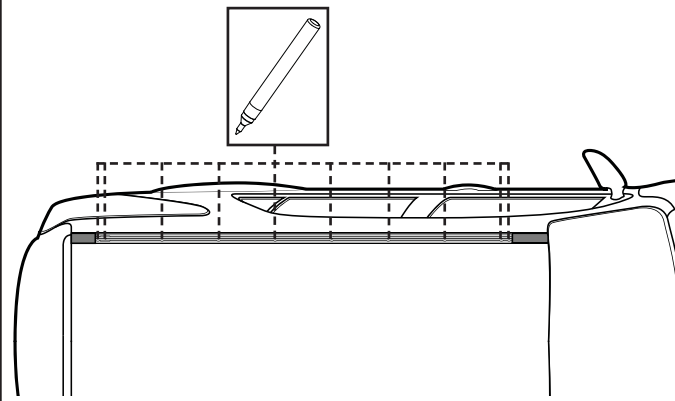

**8** Remove the Track from the ditch.

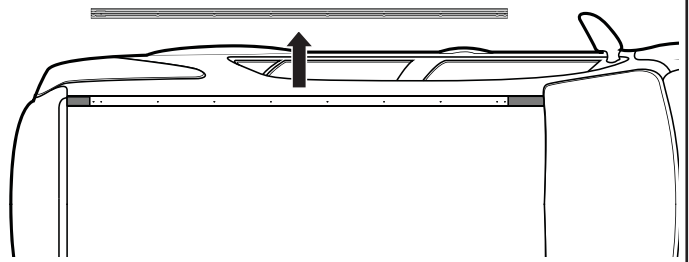

**9** Using a 5mm Drill Bit and Power Drill, drill through all marks made previous. Be sure to use a drill stop set to 5mm.

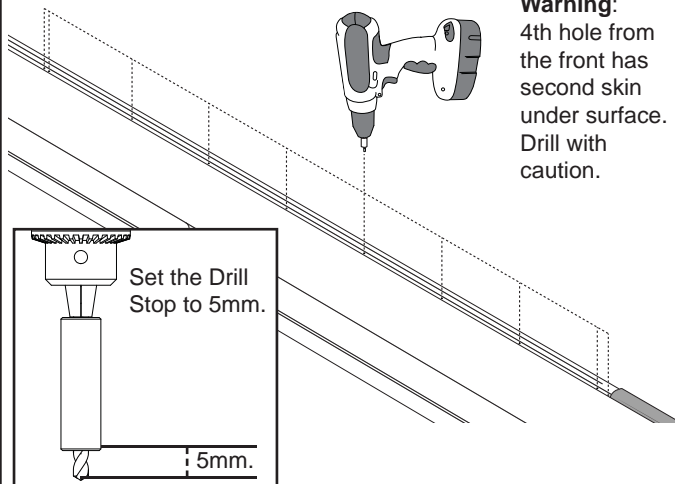

**10** 1: Vacuum any swarf from the area. 2: Using Cold Galvanising Paint, cover all drilled areas and any exposed body work.

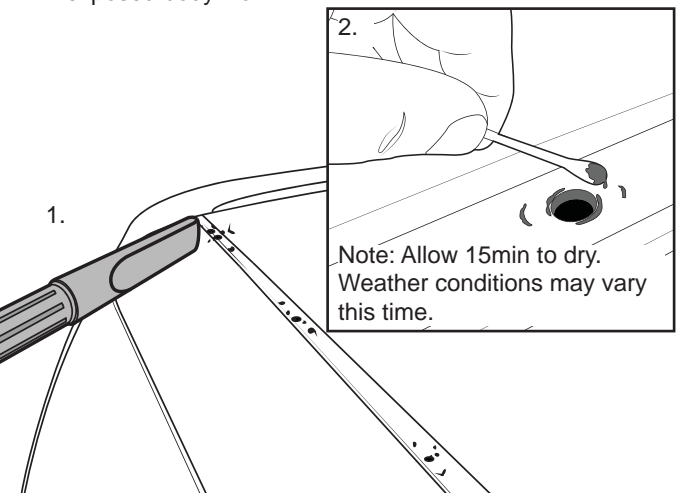



# Toyota Fortuner Trackmount Kit (RTS544)

**11** Peel off the one side of backing tape on the Butyl Patches provided. Place these carefully over all holes drilled. Remove the top layer of backing tape as shown.

2.

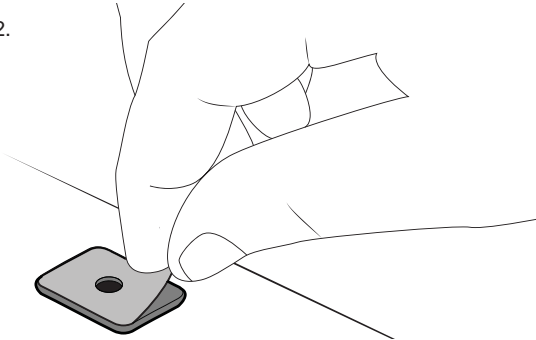

**12** Remove the tape from the Tracks.

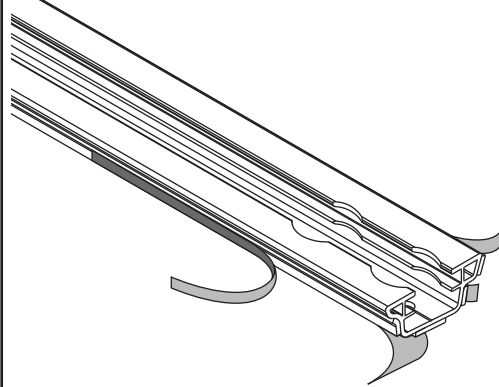

**13** Insert End Caps and install rivets into each hole.

M831 - Front Right, Rear Left  
M832 - Front Left, Rear Right

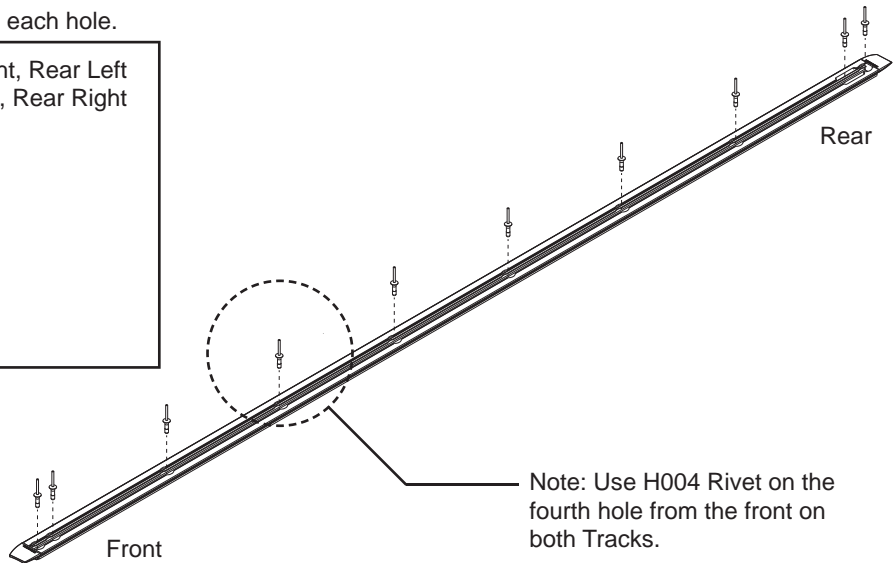
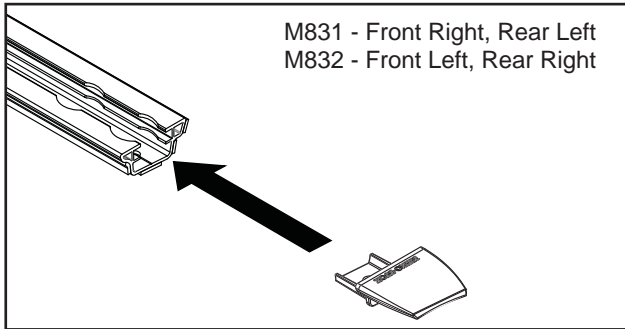

Note: Use H004 Rivet on the fourth hole from the front on both Tracks.

**14** Using either a Pneumatic or Concertina type Rivet Gun (not a small hand gun), rivet the Track into place. Make sure all Rivets are seated firmly onto the base of the Track, place the Rivet Gun onto the Rivet with a Rivet Spacer and gently tap on the back to ensure the rivet is seated before compressing. **Check Track alignment carefully before starting. Start at the front and move towards the rear.**

**Note:** The Track will stand high at the rear when installing from the front. Minor force will be needed to flex the Track down while riveting.

Place the Rivet Gun Spacer over the Rivet before fixing in place. This will prevent the Rivet Gun scratching the Tracks.

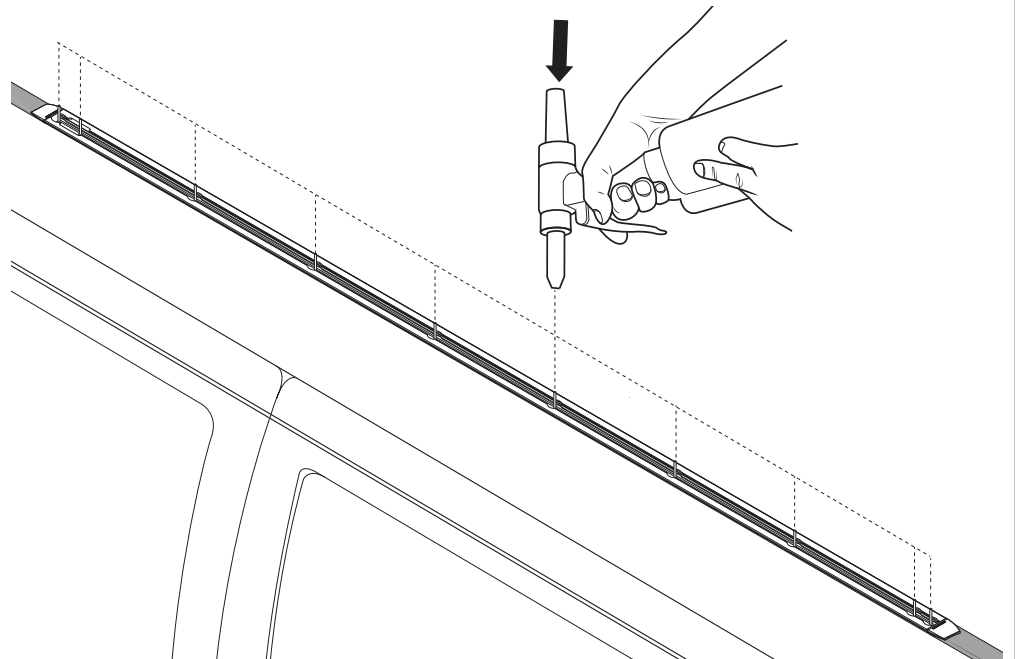
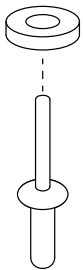

**Install Crossbars as per instructions**